

FOAMPRO®

Form 850

10/04

Systems

1600

and

1601

**INSTALLATION AND
OPERATION MANUAL**

Unit
Serial
Number

All quality FoamPro products are ruggedly designed, accurately machined, carefully assembled, thoroughly inspected and tested. In order to maintain the high quality of your unit, and to keep it in a ready condition, it is important to follow the instructions on care and operation. Proper use and good preventive maintenance will lengthen the life of your unit. ALWAYS INCLUDE THE UNIT SERIAL NUMBER IN CORRESPONDENCE.

TABLE OF CONTENTS

SECTION	PAGE
1 SAFETY	3
2 A QUICK LOOK AT HOW THE SYSTEM WORKS	4
3 SYSTEM COMPONENT DESCRIPTION	5
4 INSTALLER SUPPLIED PARTS.....	6
5 INSTALLATION PLANNING	8
6 PLUMBING COMPONENT INSTALLATION AND HOOK-UP	9
7 ELECTRICAL EQUIPMENT INSTALLATION	13
8 MAKING SURE EVERYTHING IS WORKING RIGHT	18
9 CALIBRATION AND SETUP	19
10 OPERATING INSTRUCTIONS	20
11 MAINTENANCE	22
12 TROUBLESHOOTING	23
13 PARTS IDENTIFICATION.....	25
14 INSTALLATION DRAWINGS	26
15 WARRANTY.....	BACK PAGE

NOTE TO SYSTEM INSTALLER

IMPORTANT: Please provide a copy of the FoamPro manual to the end user of the equipment. For additional manuals, contact Hypro by FAX 651-766-6614 or call (651) 766-6300. Ask for Form No. 850.

1 SAFETY

Please read all of the following safety precautions and follow carefully. They are important to the prevention of personal injury or damage to the equipment.

1. Do not pump at pressures higher than the maximum recommended pressure. [400 psi (28 BAR)]
2. Do not permanently remove or alter any guarding devices or attempt to operate the system when these guards are temporarily removed.
3. **Always disconnect the power source** before attempting to service any part of the pump. Note, this system contains a capacitor which will hold a charge for a time after the power is disconnected. Take care to dissipate this charge, by connecting a 12 or 24 volt test lamp from the pump base to the positive main power terminal.
4. **Release all pressure** within the system before servicing any of its components.
5. **Drain all concentrate and water** from the discharge system before servicing any of its component parts.
6. Check all hoses for weak or worn conditions after each use. Ensure that all connections and fittings are tight and secure.
7. Use only pipe, hose, and fittings from the foam pump outlet to the injector fitting, which are rated at or above the maximum pressure [400 psi (28 BAR) minimum] rating at which the water pump system operates.
8. Any electrical system has the potential to cause sparks during service. Take care to eliminate explosive or hazardous environments during service/repair.
9. **CAUTION:** Do not attempt to operate the system at or above a temperature of 160°F (71°C).
10. **CAUTION:** Ensure that the electrical source of power for the unit is the appropriate 12 or 24 volt, negative ground DC system, with a minimum current rating of at least 32 amps for 12 VDC or 16 amps for 24 VDC System 1600's.
11. **CAUTION:** Periodically inspect the pump and the system components. Perform routine preventive maintenance as required. Failure to perform routine maintenance may cause damage to the pump. See the maintenance section of this manual for recommended maintenance procedures and intervals between maintenance work.
12. **CAUTION:** Read and understand "Operating Instructions" section before attempting to operate the unit.
13. **CAUTION:** Always disconnect the ground straps and control cables from the control module or other FoamPro equipment before electric arc welding at any point on the apparatus. Failure to do so will result in a power surge through the unit that could cause irreparable damage to the system components.
14. **CAUTION:** The cables shipped with each FoamPro unit are tested at the factory. Improper handling and forcing connections can damage these cables which could result in other system damage.

2 A QUICK LOOK AT HOW THE SYSTEM WORKS

The FoamPro System 1600/1601 is an electric motor driven flow-based proportioning system that measures water flow and then injects the proportional amount of foam concentrate to maintain the preset percentage. The basic FoamPro 1600/1601 system is shown in Figure 1. The system will accurately deliver from 0.1% to 1.0% foam concentrate to the foam injector fitting. The flowmeter measures the water flow and sends a signal to the motor driver control. Another sensing device monitors the foam pump output. Constant comparison of these two information signals by the computer ensures maintenance of the desired proportion of foam concentrate at all times based on the water flow rate, independent of any variations in fire pump intake or discharge pressures. As water flow increases or decreases, the foam concentrate rate of injection is

increased or decreased automatically to correspond to the water flow.

Foam concentrate is injected directly into the water stream on the discharge side of the water pump. It is then fed as foam solution by the main fire pump into a standard fog nozzle, an air aspirated nozzle, or CAFS equipment.

Since foam is injected on the discharge side of the fire pump, and check valves are to be used at installation, there is no foam concentrate contamination of the booster tank, fire pump and relief valve.

Order optional system components listed in Section 3 to accommodate system design and requirements.

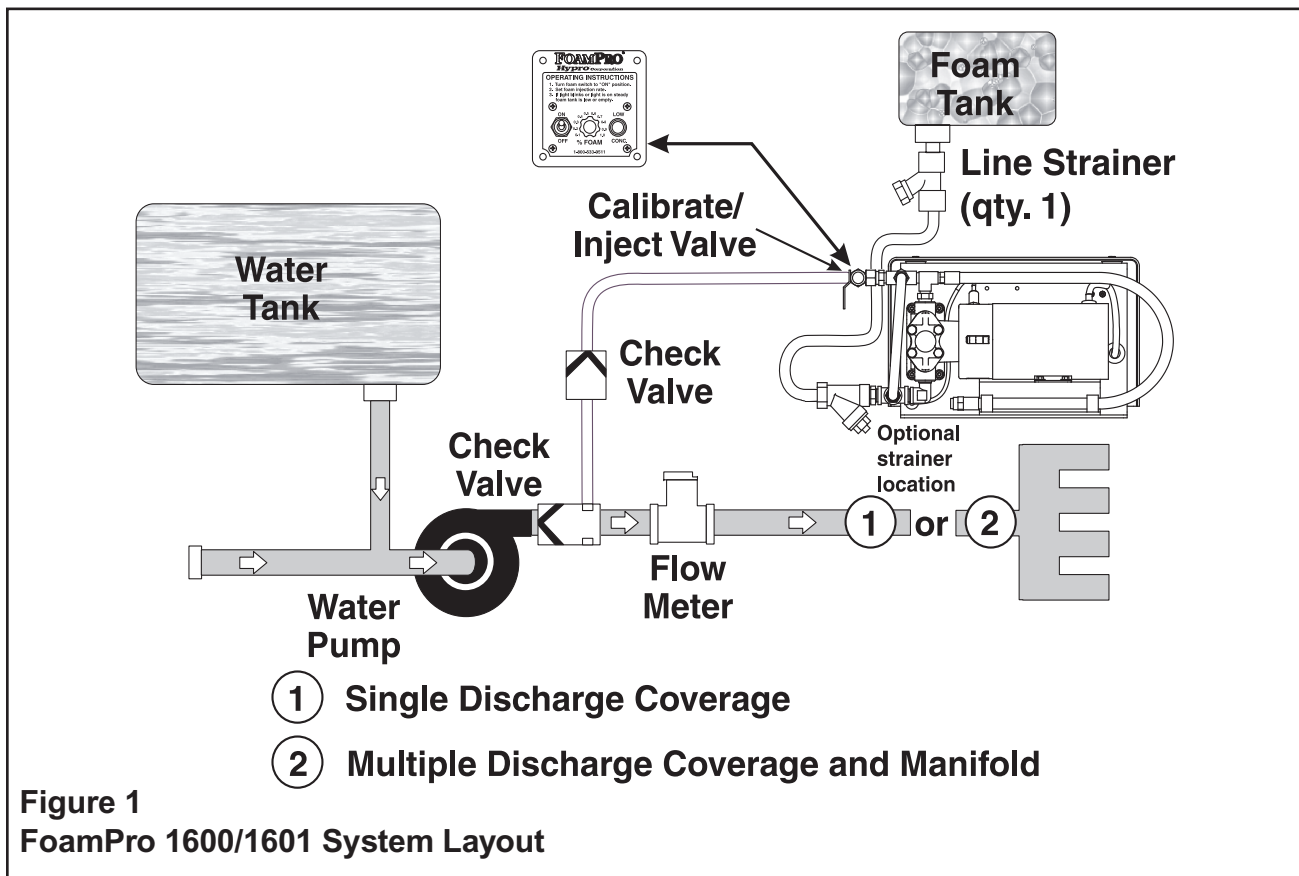

3 SYSTEM COMPONENT DESCRIPTION

STANDARD FOAMPRO 1600/1601 EQUIPMENT

The following components are packaged with the FoamPro 1600/1601:

- | | |
|--|--|
| <ol style="list-style-type: none"> 1. Control Module with Instructions 2. Molded Cables 3. Foam Pump Assembly 4. Low Tank Sensor (One required. Not packaged with the unit. Order separately.) 5. Calibrate/Inject Valve with Bushing (Attached to the pump outlet connection.) | <ol style="list-style-type: none"> 6. Inlet Line Strainer with Nipple 7. Foampro 1" bore x 1-1/2" NPT size, 1-1/2 or 2 inch NPT Paddlewheel Flowmeter. 8. 1/2 inch NPT Foam Injection Check Valve (This NFPA 1906 required check valve prevents water from back flowing into foam systems.) |
|--|--|

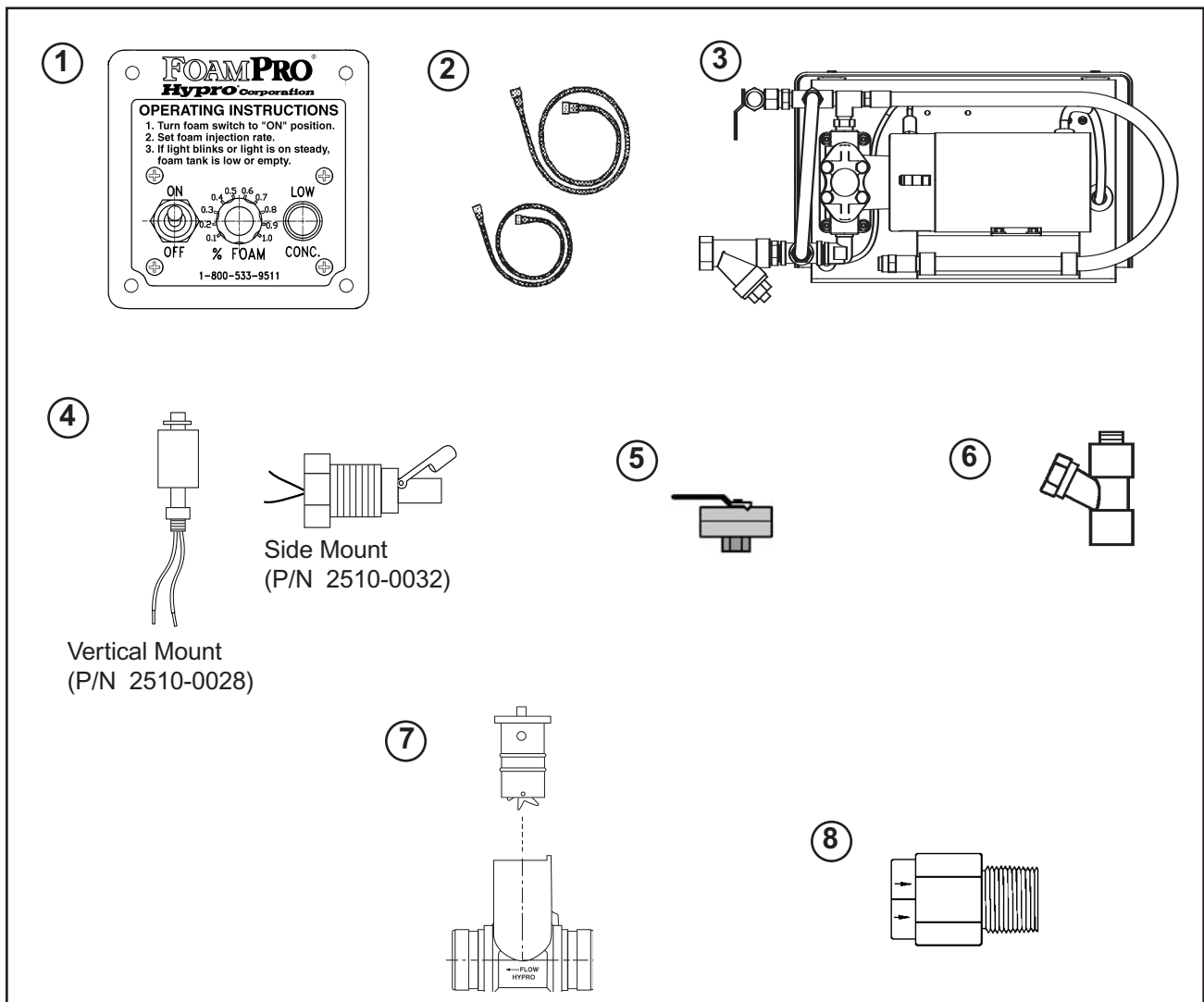

SYSTEM ACCESSORIES AVAILABLE

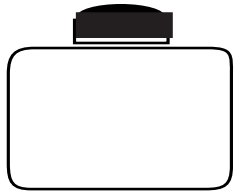

Polypropylene Foam Tank(s)

8 gallon, P/N 1530-0005
12 gallon, P/N 1530-0012
20 gallon, P/N 1530-0013

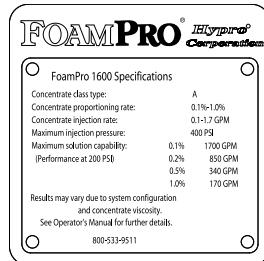

System Rating Placards

Model 1600, P/N 6032-0018
Model 1601, P/N 6032-0019

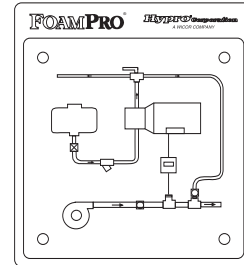

System Placard

Single Tank, P/N 6032-0015

Main Check Valve

1-1/2 inch NPT, P/N 3320-0030
2 inch NPT, P/N 3320-0031

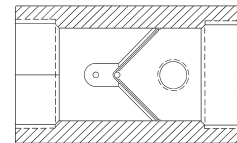

4 INSTALLER SUPPLIED PARTS

The FoamPro 1600/1601 system is provided with the major components and accessories required for installation. Due to differences in chassis and apparatus configurations, the installer must provide pipe, hoses, tubing, wire and fittings to satisfy installation requirements. The following paragraphs list the specifications for selection of these components. Before beginning system installation, read this section thoroughly to make sure the proper components are selected. For detailed system installation instructions refer to Sections 5, 6 and 7.

FOAM CONCENTRATE SUCTION LINE

Fittings and hoses from the foam tank to the inlet of the foam pump must be used. Use 3/4 inch [19 mm] minimum inside diameter or larger hose dependent on the viscosity of the foam concentrate. Use components that are rated for 23 in [584.2 mm] Hg vacuum and 50 psi [3 BAR] pressure or greater. The components must be compatible with all foam concentrates to be used. Fittings used must be made of brass, 300 series stainless steel or other corrosion resistant material. Before selection of hose fittings, check for compatibility with foam concentrates to be used. The use of clear suction hose is recommended to allow viewing foam priming operations. The foam pump must be positioned to allow gravity feed from the foam tank.

FOAM CONCENTRATE DISCHARGE LINE

Fittings and hoses from the discharge of the foam pump to the injector fitting must be supplied by the installer. Hoses and fittings of 1/2 inch [13 mm] minimum INSIDE diameter rated at 400 psi [28 BAR] minimum working pressure or maximum discharge pressure of the fire pump, whichever is greater, must be supplied by the installer. Fittings and hoses must be compatible with all foam concentrates to be used. Use fittings of brass, 300 series stainless steel or other corrosion resistant material that is compatible with all foam concentrates to be used.

CHECK VALVES

NFPA 1901 and 1906 require installation of a check valve in the foam concentrate injection line. To prevent foam concentrate flow from the tank due to static head pressure, the foam concentrate check valve shall have a 4 to 6 psig [0 to 0.3 BAR] cracking pressure and shall be capable of withstanding the pressures that will be generated in the foam injection line.

A check valve is also required in all water piping locations where foam concentrate could drain back into pumps or other components of the fire apparatus. As a minimum, one check valve must be installed where the foam solution water piping connects to the fire pump discharge (FoamPro Main Waterway Check Valve is recommended).

Multiple drains that allow individual drain lines to communicate may allow foam to short circuit past the check valves; avoid this possibility. FoamPro recommends separate drain valve(s) for the discharge piping.

FOAM CONCENTRATE TANK

A foam concentrate tank must be supplied to suit the capacity required for the apparatus application. The tank should meet NFPA minimum standards for the design capacity, including filler size, vapor pressure venting and drain facility. A shut-off valve is recommended to allow cleaning of the strainer.

ELECTRICAL REQUIREMENTS

Electrical wiring must be supplied from the main apparatus electrical system to the foam pump base unit. Use a minimum of 10 AWG wire because the FoamPro 1600/1601 requires 32 amp minimum electrical service for 12 VDC systems or 16 amps for 24 VDC systems. The electrical power must be supplied directly from the battery or the battery master disconnect switch. Braided flat ground straps are required for ground connections. The flat straps limit the RFI/EMI interference encountered with radios, computers or other sensitive electronic equipment.

CAUTION: Always disconnect the ground straps and control cables from the control module or other FoamPro equipment before electric arc welding at any point on the apparatus. Failure to do so will result in a power surge through the unit that could cause irreparable damage to the electronic components.

5 INSTALLATION PLANNING

Because of the potential differences in apparatus plumbing and foam system configuration, it is not practical to depict exactly how each FoamPro unit can best be installed onto a particular apparatus. Figure 2 shows the relative location of the FoamPro System 1600/1601 components. Most of the information contained in the following sections, however, will apply to any situation.

The Foampro manufacturer recommends that you read the following sections thoroughly before beginning installation of the FoamPro system. The manufacturer also recommends that you spend time planning and designing where and how you intend to install this unit in the apparatus before beginning the actual installation.

Determine the locations of the components to be installed such as; foam tank, foam pump and flowmeter. Try to place components in locations that require the least amount of hoses and fittings.

Position the foam pump unit in an area that is protected from road debris and excessive heat buildup. Since the master power switch and CAL/INJECT valve are located on this unit, it is

recommended that the foam pump unit be installed in an accessible compartment located in the vicinity of the operators panel.

The foam pump unit should be positioned below the discharge of the foam tank to provide for gravity feed to the foam pump. Place the foam tank where the refilling can be done with 5 gallon [19 liter] containers and other methods suitable to the end user. Most water tank manufacturers will build the foam tank into the booster tank. When specifying a integral foam tank, make sure provisions are made for installation of the low tank level sensor as well as foam suction connections and tank drainage.

Determine a location for the Control Module on the operator panel of the apparatus. Consider the routing path of the control cables from the control module to the foam pump unit and low tank sensor. If necessary, order longer or shorter cable assemblies to suit the location demands.

CAUTION: Never attempt to cut or lengthen the molded cables.

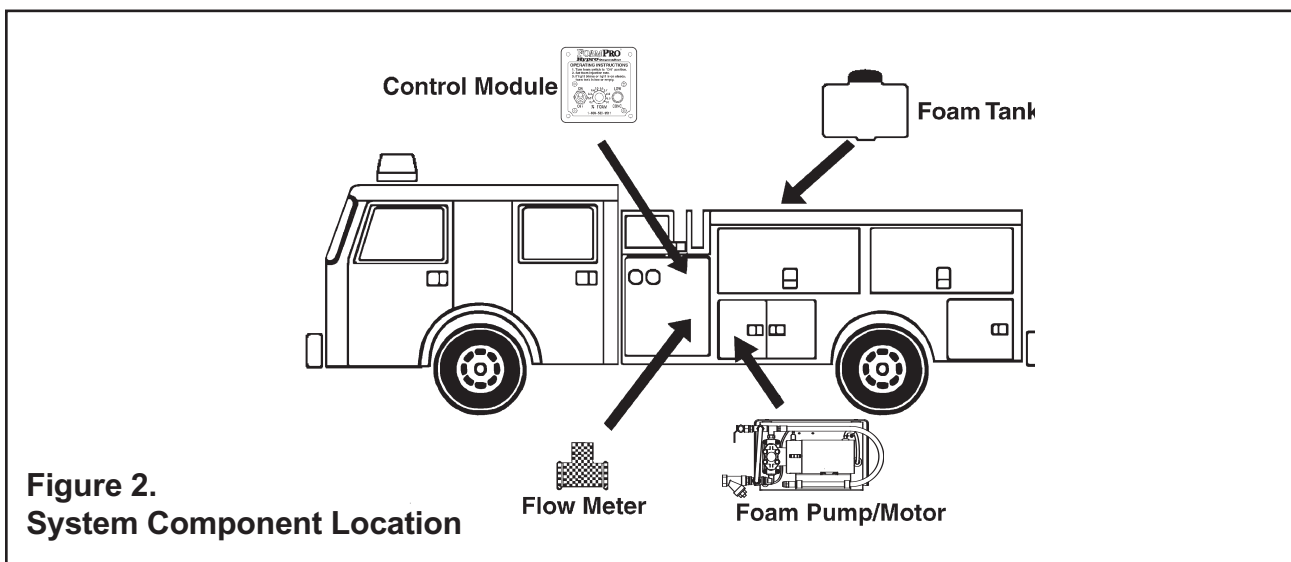

Figure 2.
System Component Location

6 PLUMBING COMPONENT INSTALLATION

The following diagram (Figure 3) provides recommended guidelines for the location of the system components that handle water, foam concentrate and foam solution.

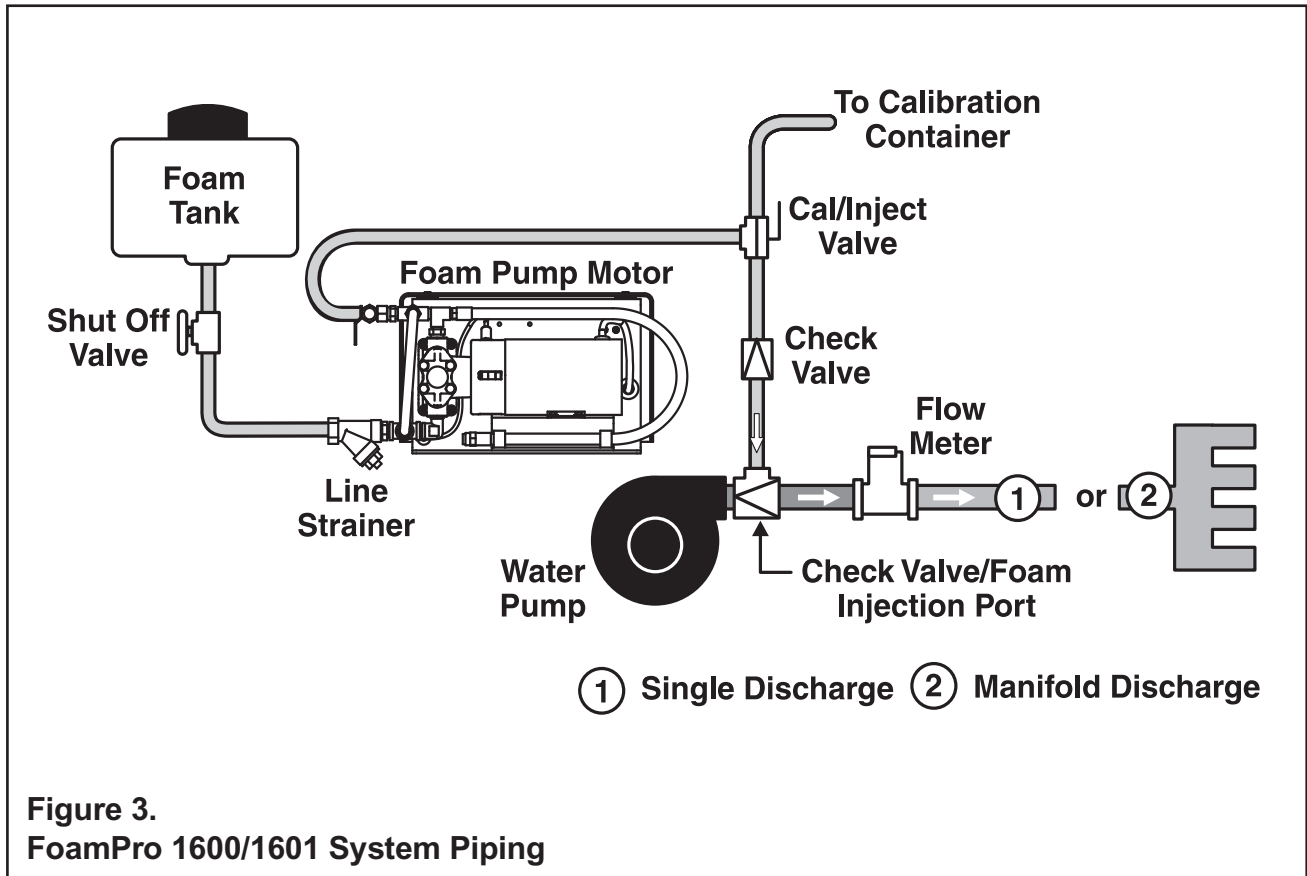

Figure 3.
FoamPro 1600/1601 System Piping

A. FOAM PUMP/MOTOR BASE ASSEMBLY

The foam pump/motor base assembly may be mounted in a horizontal or vertical position. The base of the foam pump must be anchored to a surface or structure that is rigid and of adequate strength to withstand the vibration and stresses of apparatus operation. Figure 4 provides the mounting dimensions for the FoamPro 1600/1601 foam pump/motor base assembly. Flexible hose is

required to make the hose connections to the FoamPro 1600/1601.

DO NOT hard pipe the system.

Position the foam pump so the main power on-off switch is easily accessible. Also, consider access

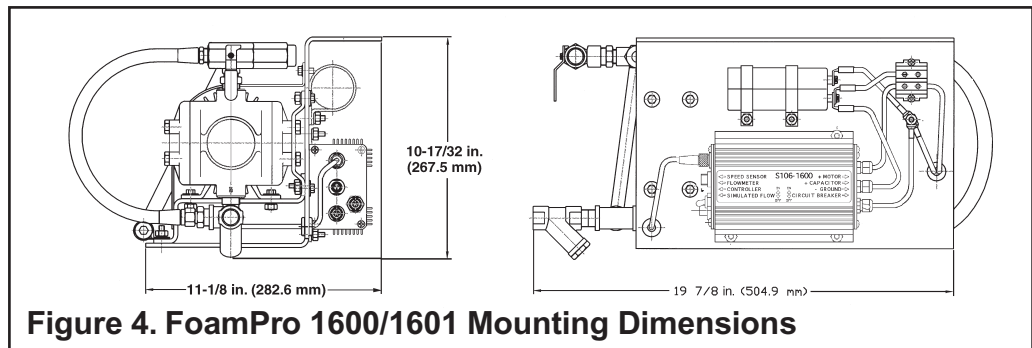

Figure 4. FoamPro 1600/1601 Mounting Dimensions

requirements for checking and greasing the cam bearing of the foam pump. Be sure the foam concentrate hoses can be properly routed to the inlets and outlets on the foam pump. Foam concentrate should gravity feed to the foam pump inlet from the foam tank. The foam pump/motor base assembly must be mounted in an area to avoid excessive exhaust system heat buildup.

Protect the hoses and wiring to prevent chafing and abrasion during operation of the foam system.

Protect the foam pump base unit from excessive road spray and debris. Although the system is sealed and designed to be resistant to the harsh environment of fire fighting apparatus, a protected compartment with easy operator access is the recommended installation location.

B. DISCHARGE RELIEF VALVE

The discharge relief valve is installed on the outlet port of the foam concentrate pump. It is provided to protect the foam pump from excessive pressures. The relief valve is factory set at 400 psi [28 BAR].

C. CAL/INJECT VALVE

The CAL/INJECT valve is mounted on the discharge side of the foam proportioner. This valve shall be accessible by the pump operator during normal operations. The valve is a 3-way directional valve that selects where the output of the foam pump will go.

Check to make sure the valve is installed properly. Look at the ports as you move the handle, the flow should go from the center port to each of the other ports.

The hose and fittings from the INJECT port to the foam injector fitting should have 1/2 inch [13 mm] inside diameter and be rated at 400 psi [28 BAR] minimum working pressure or maximum discharge pressure of the fire pump.

The hose from the CAL/FLUSH port may have a lower pressure rating since it is plumbed to the atmosphere and will not receive high pressures.

This hose is used for calibrating the foam pump, pumping the concentrate into a container to empty the tank or to assist in priming of the foam pump. The hose from the CAL/FLUSH port must be long enough to reach a container outside the truck. This hose must be coiled for storage when not in use.

D. LINE STRAINER

The line strainer that is provided with the FoamPro unit has 3/4 inch NPT female threaded ports and is installed on the inlet port of the foam pump. The hose from the foam tank should have adequate wall stiffness to withstand the vacuum of the foam pump while it is operating (23 in. [584 mm] Hg and 50 psi [3 BAR]).

NOTE: If a pressurized water flush from one of the discharges is incorporated, the plumbing and line strainer exposed to this pressure must be rated at or above the operating pressure of all other discharge plumbing components. (400 psi [28 BAR] minimum).

E. FLOWMETER

The FoamPro System 1600/1601 is designed to accept flow reading signals from the FoamPro paddlewheel style flowmeter.

The flowmeters require that the amount of turbulence in the pipe being monitored is as low as possible. Excessive turbulence produces unstable and inaccurate flow readings. The following installation guidelines will help attain the best readings and maintain accuracy of the FoamPro system.

- a. A minimum of **5 times the pipe diameter** of straight run pipe without any fittings is necessary upstream of the flowmeter. **10 times** is even better — the longer the straight run, the lower the turbulence.
- b. The downstream plumbing of the flowmeter is not as critical; but again, straight runs without fittings help maintain accurate flow readings.

- c. **Do not mount a flowmeter directly after an elbow or valve.** Valves create severe turbulence when they are “gated-down”.
- d. Last, try to mount the flowmeters in a position that is accessible for routine inspection and maintenance.

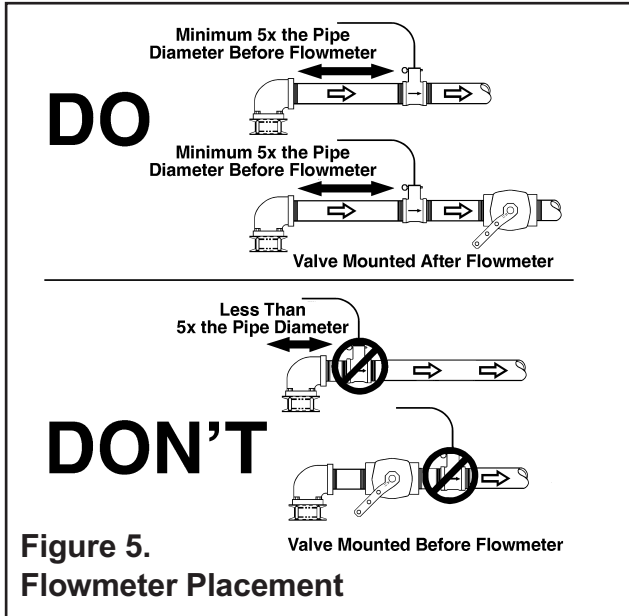

FOAMPRO PADDLEWHEEL FLOWMETERS

The FoamPro paddlewheel style flowmeter fittings are specially designed tees that make inspection and maintenance of the flow sensor easy. The threads of the tees are NPT. In horizontal runs the tees should be mounted as close to upright as possible within the range shown in Figure 6.

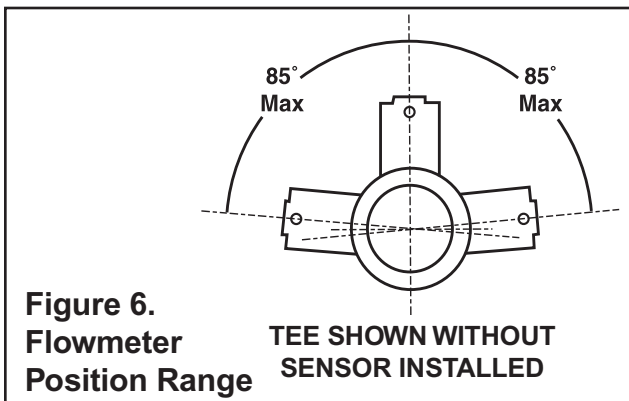

F. INJECTOR FITTING

The brass injector fitting ensures the foam concentrate is injected into the center of the water flow for better mixing. The inlet of the fitting is 1/2

inch NPT female thread, and the outer threads are 1 inch NPT designed to fit a pipe tee that is installed in the discharge piping of the fire pump (see Figure 7). The injector may also be inserted into a weld fitting with 1 inch NPT female threads. It **MUST** be mounted in a place that is common to all discharges which require foam capability.

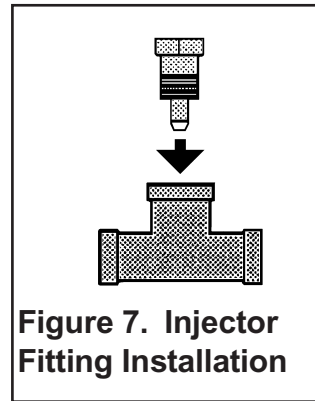

This fitting is not used if using a FoamPro Main Waterway Check Valve. A separate injection point is not possible for each discharge (see Figure 8). Most foam concentrates by nature mix with water very quickly, so each discharge from a manifold will receive equal concentrations if the manifold is properly designed and installed.

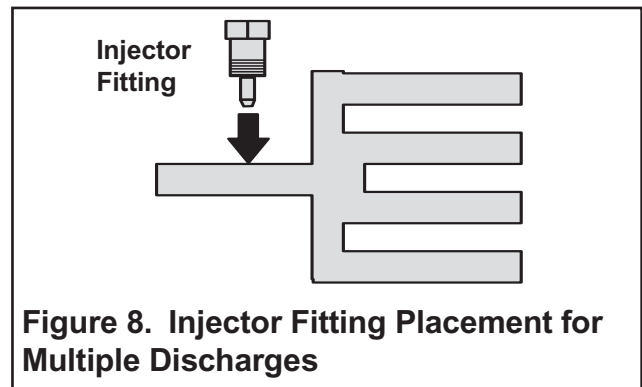

G. CHECK VALVES

A 1/2 inch NPT check valve meets NFPA requirements for a non-return device in the foam injection system. This prevents foam concentrate from flowing from the foam concentrate tank into the main waterway due to static head pressure, the foam concentrate check valve shall have a 4 to 6 psi [0.1 to 0.3 BAR] cracking pressure and shall be capable of withstanding the pressures that will be generated in the foam injection line. It is always a good idea to inject foam at a horizontal or higher angle to allow water to drain away from the check valve (see Figure 9). This will avoid sediment deposits or the formation of an ice plug.

DO NOT OVERTIGHTEN.

The check valve in the water way is required to keep foam solution out of the main pump and allow pump priming without drawing foam into the piping.

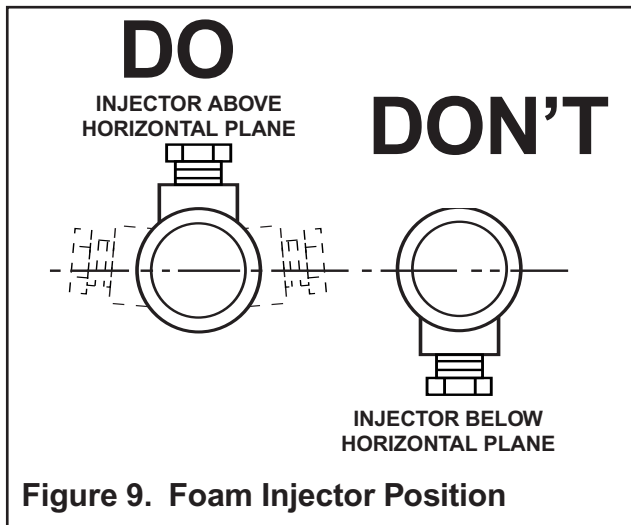

Figure 9. Foam Injector Position

H. DRAIN LINES

On apparatus with multiple drain lines, the drains from the foam solution discharge line should not be piped into a multi drain system before the check valves. The standard multi drain system from most manufacturers will allow cross talk between the drain lines and the apparatus water tank, resulting in contamination of the water tank with foam. A separate drain system should be provided for foam solution piping to prevent contamination of the water tank and fire pump.

I. FLUSHING SYSTEM

Depending on the corrosiveness of the foam concentrates to be used, a flushing system may be required in the foam concentrate injection system. Most Class A foam concentrates are less corrosive and therefore may not require flushing.

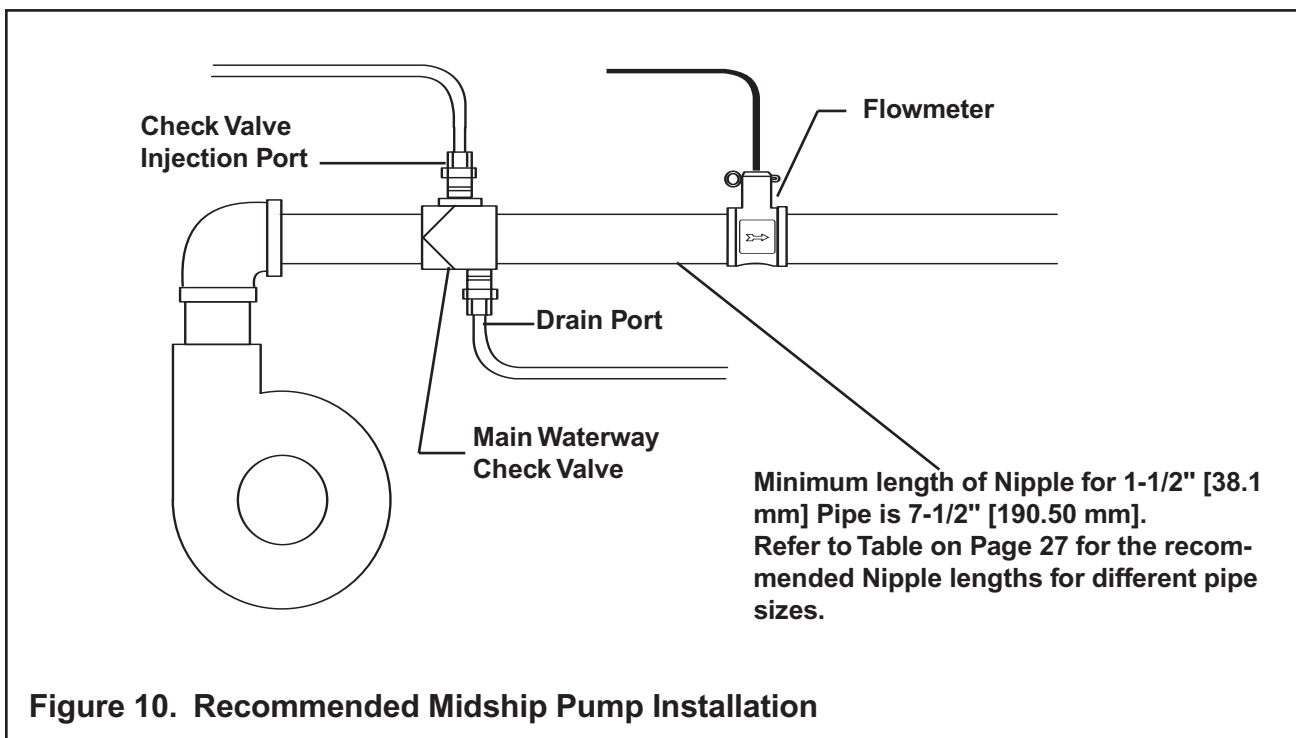

Figure 10. Recommended Midship Pump Installation

7 ELECTRICAL EQUIPMENT INSTALLATION

ELECTRICAL CONNECTIONS

Follow the system electrical diagram (Figure 11) for proper hookup of each of the electrical components. Complete molded cable sets are provided with each FoamPro system to make all the necessary connections. The cables are color coded and "indexed" so they only go in the correct receptacle and they can only go in one way. **DO NOT FORCE MISMATCHED CONNECTIONS.** *The system can only perform when the electrical connections are sound, so make sure each one is right.*

SOME THINGS TO KEEP IN MIND

- **DO NOT** hook up the main power cables until all of the connections are made to each of the electrical components. The last connection should be the power cable to the foam pump/motor base assembly.
- **WARNING:** This system contains a capacitor on the input power. Connect the leads with the battery off or disconnected. Current will flow even with the master ON/OFF switch.
- **DO NOT** cut molded cables.
- Make sure you provide at least 32 amps of electrical power for 12 VDC systems or 16 amps for 24 VDC systems from the battery to the main power terminal. Use 10 AWG (minimum) wire directly to the battery or battery switch.
- This system is designed for 12 or 24 volt negative ground direct current systems only.
- Do not mount the radio transmitter or transmitter cables in direct or close contact with the FoamPro unit.

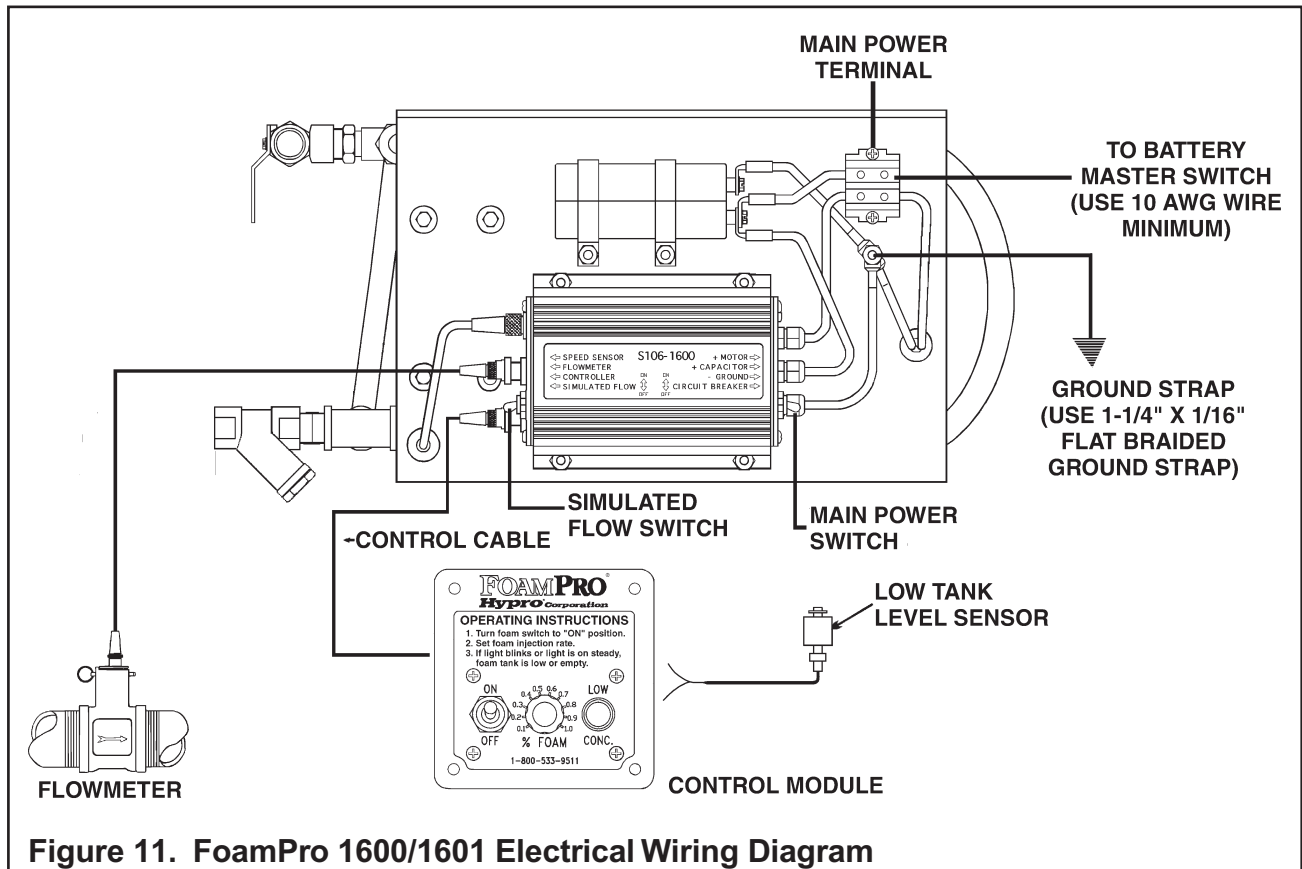

- Use care when installing molded cables. Count pins or check color codes before connecting. Bent pins caused by improper hookup can prevent proper operation even when cables are reattached properly.
- Before connecting the molded cables, inspect the yellow seal washer in the female connector. If the seal washer is missing or damaged, water can enter the connector and cause corrosion of the pins and terminals that will cause system failure.
- **CAUTION:** The cables shipped with each FoamPro unit are tested at the factory with that unit. Improper handling and forcing connections can damage these cables which could result in other system damage.
- **CAUTION:** Always disconnect the ground straps and control cables from the control module or other FoamPro equipment before electric arc welding at any point on the apparatus. Failure to do so will result in a power surge through the unit that could cause irreparable damage to the system components.

A. CONTROL MODULE

The control module is designed to be mounted in the operator panel of the apparatus. The cutout needed in the operator panel is found on Page 26 of this manual. The module is secured with four #10 socket head screws in the four holes in the face (See Page 26 for a mounting template). The display requires 5 inches [127 mm] minimum from the back of the operator panel to clear wires and connectors. Make sure there is enough clearance behind the operator's panel for the cables. Once the control module is mounted, connect the control cable (red coded cable end) from the motor driver box terminal to the 5 pin connector on the back of the control module (see Figure 12). A color coded decal on the motor driver box identifies each cable connection (see Figure 13).

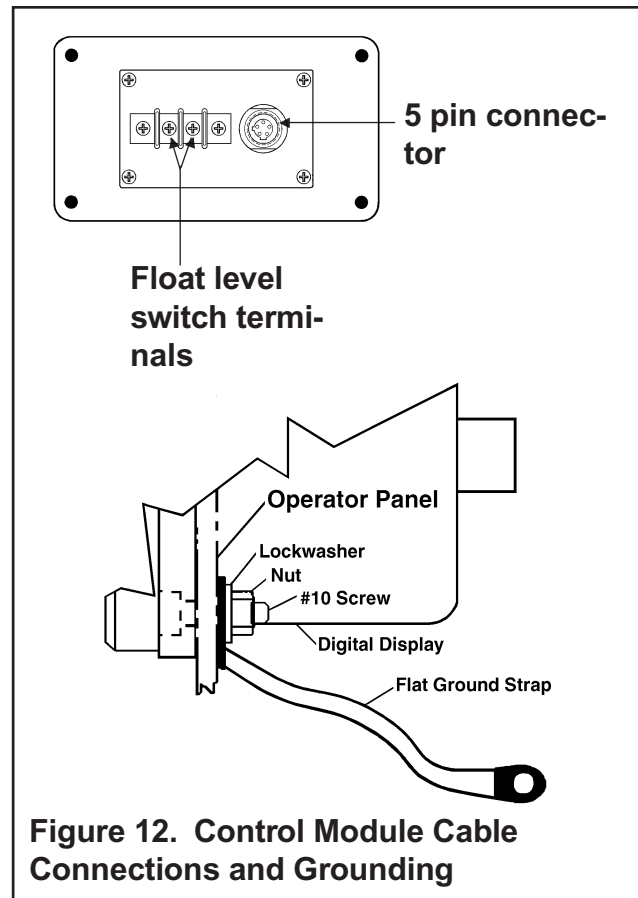
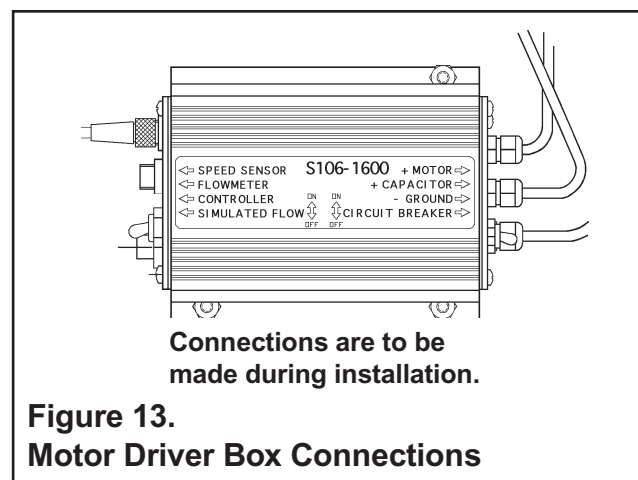

Figure 12. Control Module Cable Connections and Grounding

NOTE: Make sure the panel where the control module is mounted has an adequate ground. For stainless steel and vinyl coated panels, a flat ground strap must be attached from one of the four screws holding the control module in place, to the frame of the fire truck to ensure adequate grounding (see Figure 12).



Connections are to be made during installation.

Figure 13. Motor Driver Box Connections

B. FLOWMETER CONNECTION

FOAMPRO FLOWMETER

A molded cable is supplied, which connects from the flowmeter to the 3 pin connector on the motor driver module.

C. FOAM TANK CONNECTIONS

The foam tank low level sensor must be mounted into the bottom of the foam tank to monitor low foam concentrate level. The switch has 1/8 inch NPT threads. Mount the sensor in the bottom of the foam tank in an upright position. Use a suitable sealant to prevent concentrate leakage. There must be space under the tank for the cable to be routed to the pump base assembly. Be sure not to remove the float from the shaft on the sensor assembly. If installed in the reverse position, the control module light will blink once per second or remain on, and the system will automatically shut down after two minutes even if there is foam in the tank.

When the bottom of the foam tank is not accessible, the low level sensor float switch can be hung from a long nipple attached to the top of the tank. Take care to ensure the nipple is rigid enough to withstand the force of sloshing foam when the vehicle is in motion. Make sure the low level sensor does not contact the side of the foam tank when the vehicle is in motion. Since wire connections must be made inside the nipple, a 3/8 inch NPT nipple with 3/8 by 1/8 inch NPT reducer at the lower end is the minimum size recommended.

CAUTION: The foam tank low level sensor must be utilized to protect the foam pump from dry running. Failure to do so will void the warranty.

Connect the sensor wires to the low tank sensor cable connectors on the control module. The low tank switch sensor cable may be shortened or spliced longer (use 18-22 AWG). It has pigtails at one end and is **not** polarity sensitive.

Check low level sensor operation after installation using a powered test light. With no foam in the tank, the light should be on. If this is not the

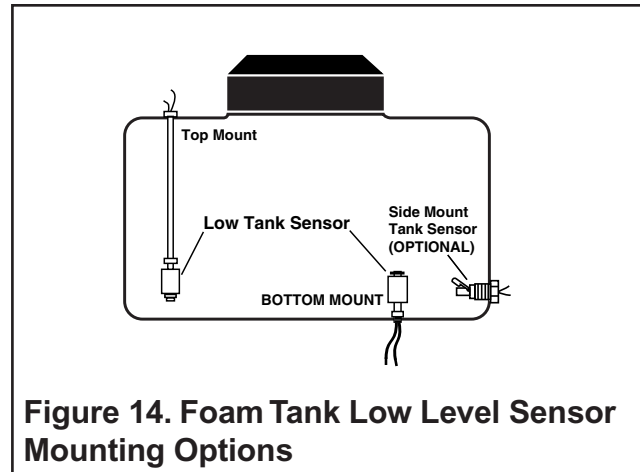

Figure 14. Foam Tank Low Level Sensor Mounting Options

case, remove the clip from the end of the sensor. Remove the float and reinstall 180° out of position. Reinstall clip.

NOTE: When the low tank sensor senses a low concentrate condition, the system will operate for two minutes unless the foam concentrate level is restored. If the foam concentrate level is not restored, the system will shut down after two minutes.

A side mount low tank sensor is available to be used if both the top and bottom of the tank is not accessible. The side mount low tank sensor has 1/2 inch NPT threads and the center of the switch must be located approximately 2 inches [51 mm] from the bottom of the foam tank with the float positioned on top of the switch to move up and down.

The side mount low tank sensor must be sealed with a suitable sealant to prevent concentrate leakage. After installation, check operation of the side mount low tank sensor with a powered test light. With no foam in the tank, the light should be on. If light does not come on, rotate the side mount low tank sensor until the test light is on. The float should be allowed to swing up and down freely.

D. DC MOTOR

Make sure you provide adequate electrical power (32 amps minimum for 12 VDC or 16 amps for 24 VDC) from the battery. Use 10 AWG minimum wire directly to the battery or battery switch. Long wire runs may require 8 AWG wire for proper operation.

Recommended wire sizes

Wire Size	Wire Length (approx.)
10 awg.	10 feet or less
8 awg	10-20 feet
6 awg	20 feet or more

E. POWER SUPPLY

Electrical devices can be easily damaged by a weak or erratic power supply. The FoamPro 1600/1601 system is no different — the better the power supply, the better the FoamPro 1600/1601 will perform and survive. At maximum output, the FoamPro 1600/1601 system can draw 32 amps at 12 VDC or 16 amps at 24 VDC.

ALWAYS connect the primary positive lead from the terminal block to the master switch terminal or the positive battery terminal. Use 10 AWG or larger chemical resistant wire and protect with a loom.

Connect the ground lead from the chassis frame or the negative battery terminal to the ground stud located on the FoamPro 1600/1601 foam pump assembly. Use the same size wire as the power lead and bare metal connections.

DO NOT connect the main power leads to small leads that are supplying some other device such as a light bar or siren.

CAUTION: The wires between the terminal block and capacitor, as well as the input power wire, are not protected by the system circuit breaker. Be careful not to damage or short circuit these wires.

F. EMI/RFI SUPPRESSION

An EMI/RFI (Radio Frequency Interference) suppression kit is included with each FoamPro 1600/1601. The clamp-on beads included in the kit, when properly installed, along with proper grounding of components will reduce the potential for radio frequency interference. Additionally, make sure radio cables and hardware are not located in the immediate area where the FoamPro 1600/1601 equipment is mounted.

Install clamp-on beads at the locations indicated in Figure 15. A small amount of silicone adhesive is necessary to ensure that the beads will not move after installation. Use GE SILICONE II, electrical tape or heat shrink tubing to keep the beads from moving after installation. The clamp-on beads must be slid up as close as possible to the connectors on the cable.

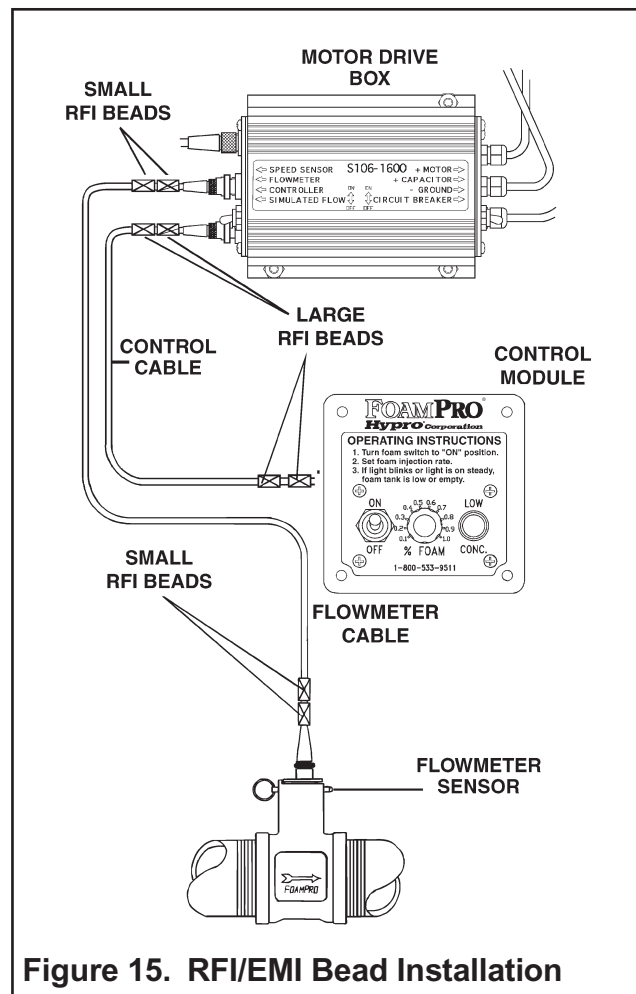

Figure 15. RFI/EMI Bead Installation

FLOWMETER AND CABLES

The flowmeter tee must be grounded. If metal piping is used, sufficient grounding may be present. However, Victaulic joints, plastic pipe and rubber mounted pumps interfere with proper grounding and an additional ground strap is required. Connect a braided ground strap at least 1/4 inch [6 mm] wide from the flowmeter tee to the apparatus frame to ensure proper grounding. A #6-32 UNC tapped hole is provided on the flowmeter tee for attaching the ground strap.

Making round coils of extra control and flowmeter cables in the pump compartment can act as an antenna. While the flowmeter and control cables cannot be shortened, various lengths of cable are available to minimize the “extra” cable in the truck. (See parts list in Section 13 for part numbers of different size control and flowmeter

cables.) When routing control and flowmeter cables, take care to avoid routing them next to antenna cables, radio power lines and radio components. When there is extra cable, double the cable back on itself and secure in a flat bundle with plastic wire ties instead of making a round coil (see Figure 16).

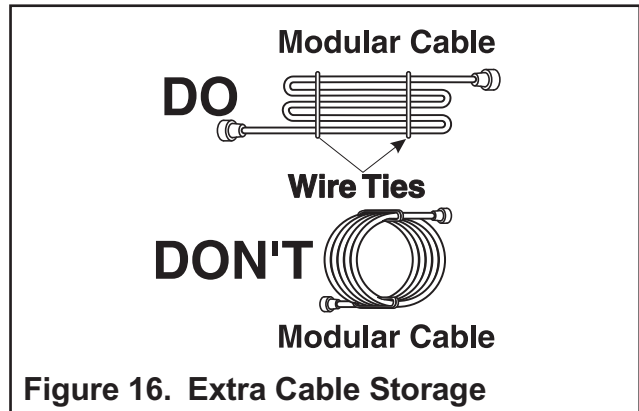

Figure 16. Extra Cable Storage

8

MAKING SURE EVERYTHING IS WORKING RIGHT

Electrical

- Tank level sensor is connected and the connections are sealed from moisture.
- Module connectors are correct and tight.
- Cable connections at the motor driver box are correct and tight.
- Flowmeter cable is properly connected to the Motor Driver Module and is tight.
- All cables and wires are secured and protected by loom from damage during operation.
- RFI/EMI beads are installed; control and flowmeter cables are properly folded and secured; radio antennas, power lines and equipment are away from control and flowmeter cables.
- All components, Control Module, Flowmeter Tee, Pump Base, etc., are properly grounded with adequate size wire and bare metal connections.
- Adequate current capacity, 32 amps minimum for 12 VDC systems or 16 amps for 24 VDC systems, is available for the foam pump motor.
- Main switch on the motor driver box is in the ON position.

Liquid

- Flowmeter is mounted with flow arrow in the correct direction for water flow.
- Check valves are properly mounted in water and foam concentrate lines.
- Strainer is properly mounted for the direction of concentrate flow in the foam tank to pump line.
- Foam tank to the foam pump valve is in place and open.
- Injector fitting lines are proper size and connections are tight.
- CAL/INJECT valve is properly mounted and oriented for direction of concentrate flow.
- The injector is in a common point to supply foam concentrate to all discharges specified to have foam capability.
- Fill foam tank with a sufficient quantity of foam concentrate or water to allow system calibration. Minimum of 5 gallons required .
- Foam is properly primed.

SYSTEM POWER CHECK

Turn the main power on/off switch on the motor driver module to the ON position. Turn the Control Module switch to the ON position. The LOW CONC. light will flash momentarily. This indicates the system is ready to operate.

FOAM PUMP PRIMING CHECK

Turn the CAL/INJECT valve to the CALIBRATE or FLUSH position. Provide a container to collect the output that will be coming from the foam pump.

Turn the INJECTION RATE knob to the 1.0% setting. Place the system into "simulated flow" and engage the FoamPro system at the control module.

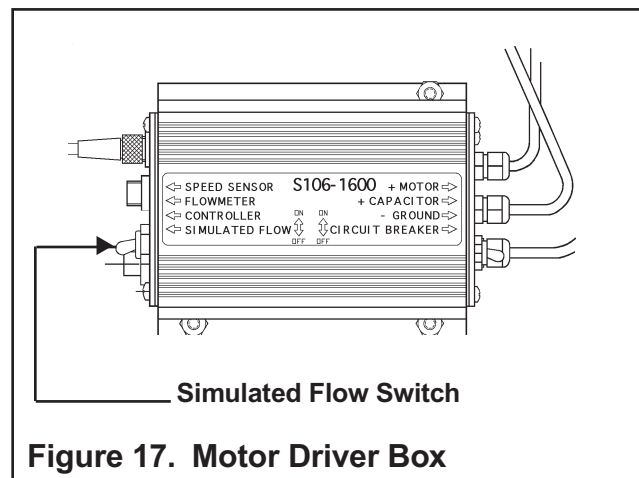

Figure 17. Motor Driver Box

- Foam concentrate should begin flowing into the container. If concentrate is not being pumped, check first to make sure the foam pump is running. If the pump is running, but no concentrate is being delivered, then the pump is most likely not primed completely. If the pump does not prime within 20-30 seconds, disengage the system by turning the switch off.
 - If the system has been installed properly, foam concentrate should flow readily to the pump.
 - Once foam flow is established, turn the system off and turn the CAL/INJECT valve back to the inject position.
 - Turn the simulated flow switch off.
- If you are still having difficulty priming the foam pump in your FoamPro system, do the following:
- Make sure foam concentrate tank shutoff valve is open.
 - Check to make sure there are no restrictions from the concentrate tank to the inlet of the foam pump.
 - Check to make sure there are no leaks in the plumbing where air can enter the pump.

9 CALIBRATION AND SETUP

CALIBRATION

The FoamPro System 1600/1601 and flowmeter have been calibrated at the factory. To recalibrate the system, the following procedure may be followed:

1. Turn the CAL/INJECT valve to the CALIBRATE or FLUSH position. Provide a container to collect the output that will be coming from the foam pump.
2. Start the main water flow and set it to a known rate and pressure.
3. Set the injection rate to any specific setting (usually 0.5% or 1.0%).
4. Turn on the Model 1600/1601 and run it for 3 to 5 minutes. Foam will pump into the container.
5. Measure the amount of foam in the container and compare that to the calculated amount (main flow rate X injection rate X minutes flowed [100 gpm X 0.005 (0.5%) injection rate X 5 minutes = 2.5 gal. output]). If the amounts are significantly different, remove the small black screw and o-ring on the motor driver box with a 3/32 allen wrench (see Figure 18). With a small slotted screwdriver, adjust the screw inside the driver module. If the measured flow is above what is expected, turn the screw clockwise. If the measured flow is below what is expected, turn the screw counterclockwise.
6. Repeat Steps 1 through 5 again and make any further adjustments required.
7. Replace the adjustment cover screw after calibration has been completed. This keeps water and dirt from entering the driver module and prevents serious damage to the unit.

NOTE: The viscosity of different foam concentrates may have an effect on the amount of foam concentrate that is injected into the water stream. When calibrating the system, use the foam concentrate that will be used most frequently during normal operations. When different viscosity foam concentrates are used, the actual concentrate injection may vary as much as 10%.

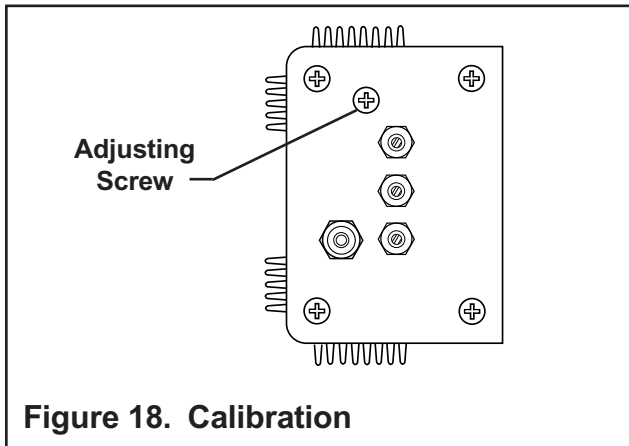

Figure 18. Calibration

PRESSURE RELIEF VALVE ADJUSTMENT

The pressure relief valve is factory tested and preset at 400 psi (28 BAR). During normal installation and operation the relief valve will not require adjustment. The following procedures are provided if adjustment is necessary in field installation. DO NOT set the relief valve above 400 psi [28 BAR].

Perform this adjustment after the foam pump has been primed.

1. Determine the maximum pressure that will be needed to discharge foam solution. (For example: The maximum foam injection pressure should be approximately 50 psi [3.5 BAR] higher than the maximum operating pressure as set forth by department policy.)
2. Gather the items required for reading con-

centrate injection pressure. A 0-500 psi [0 to 34.5 BAR] test quality gauge, 500 psi [34.5 BAR] hoses and fittings to connect to the injector line from the foam pump.

3. Disconnect the injector from the foam line and connect the pressure gauge to it.
4. Screw the pressure adjustment nut on top of the valve all of the way down until it stops.
5. Unscrew the pressure adjustment nut counterclockwise 10 full turns. This will place it in a position to relieve at low pressure.

CAUTION: DO NOT run FoamPro 1600/1601 for more than one minute dead headed against the pressure gauge as the foam pump will overheat.

6. Operate the foam pump as described in the Foam Pump Priming Check Section.
7. While the foam pump is running, slowly screw the Pressure Adjustment Nut down clockwise until the desired pressure is reached. Apply tamper proof type sealant to pressure relief valve adjustment nut so that it does not move accidentally.
8. Stop the foam pump.

WARNING: Slowly loosen the foam pressure line fittings and allow the pressure to escape. Protect face and eyes from any potential spray which may occur.

9. Reconnect the foam line to the injector fitting. The pressure relief valve is now set.

10 OPERATING INSTRUCTIONS

NORMAL SYSTEM OPERATION

Once the system has been set up and calibrated, operation is very simple and is controlled by the ON/OFF switch and the INJECTION RATE knob on the control module.

When the FOAM switch is toggled into the ON position, the LOW CONC. light momentarily flashes on. This indicates that the system is ready to operate. The FoamPro system monitors the water flow and controls the foam injection at the specified concentration selected.

The foam injection rate can be adjusted at any time during operation to suit the conditions and/or concentrate being used.

DISPLAY MESSAGES

Several safety features are provided to protect the foam concentrate pump and motor and help diagnose problems in system operation. The display method used in the MODEL 1600/1601 is done with the usage of the LOW CONC. light and are described on the following page.

LIGHT STATUS	SYSTEM CONDITION
Light blinks on and then goes out.	System is activated and ready to run, and/or running depending on the main water flow conditions.
Light goes on and stays on.	System is activated and ready to run, but it has insufficient concentrate in the tank.
Light does not turn on at all on start-up.	System is turned off at the motor driver module. Poor ground. Control module is not properly connected. Internal fuse is tripped, check flowmeter. No power or insufficient power to unit.
Light blinks once per second after successful start-up.	A low concentrate condition has been detected. The light will blink for two minutes and then shut the foam pump off unless sufficient foam level is restored.
Light is on solid after successful start-up and operation.	System has been out of chemical for more than two minutes and the foam pump is not operating.
Light blinks five times per second.	No pump feedback is detected and a problem exists at the speed sensor. Insufficient ground.

Simulated Flow Operation

The Simulated Flow function of the system allows the operator to control the foam pump manually. The water flow rate is factory set at approximately 100 gpm; the percentage rate can be adjusted at the control module. This function provides the manual control requirement of NFPA. This function allows the operator to empty the foam concentrate tank for cleaning or changing foams. It also provides a means of checking the foam

pump without running the water pump.

WARNING: When operating the FoamPro in the Simulated Flow function, an outlet for the foam concentrate must be provided. Otherwise, dangerous excessive pressure may be built up in the apparatus water piping and/or hoses.

Simulated Flow Operation Procedure

To begin simulated flow:	Turn the switch to the “ON” position located on the left side of the motor driver.
To adjust the percentage of concentrate:	Adjust the percentage on the control module.
To exit the simulated flow:	Turn the switch to the “OFF” position located on the left side of the motor driver.

11 MAINTENANCE

1. **Monthly:** Inspect wiring, hoses, flow meters, and connections for tightness, corrosion, leaks and/or damage.
2. **Monthly:** Lubricate the cam bearing of the foam pump with a push-type grease gun (DO NOT USE AN AIRPOWERED OR HIGH PRESSURE OPERATED GREASE GUN) using a high quality wheel bearing grease. Do not grease excessively.
3. **Monthly:** Remove and clean the foam strainer screen. Flush as required.

With a screwdriver or flat tool, apply a generous dab of grease to the outer diameter surface of the cam bearing at the points where the bearing contacts the connecting rod.

Check periodically and scrape out (do not wash out) any excessive grease from the pump cavity. Replace the protective cover after greasing and/or inspection.

NOTE: Water quality, flushing & storage techniques, environment and usage may have an effect on your maintenance schedule. To ensure equipment longevity, it is recommended to adjust your schedule accordingly.

CAUTION: Release all pressure and drain all concentrate and water from the discharge system before servicing any of its component parts.

12 TROUBLESHOOTING

The FoamPro 1600/1601 System is designed to be easy to diagnose and service. There are several major components. Servicing the system involves isolation of the failed component and replacing it. There are no user serviceable internal components in the electronic modules. Due to the reliable nature of modern electronics, most failures are traced to faulty cables or wiring problems. Following the troubleshooting guide will allow quick diagnosis of the problem and the corrective action to take. (See the Troubleshooting Guide on page 24.)

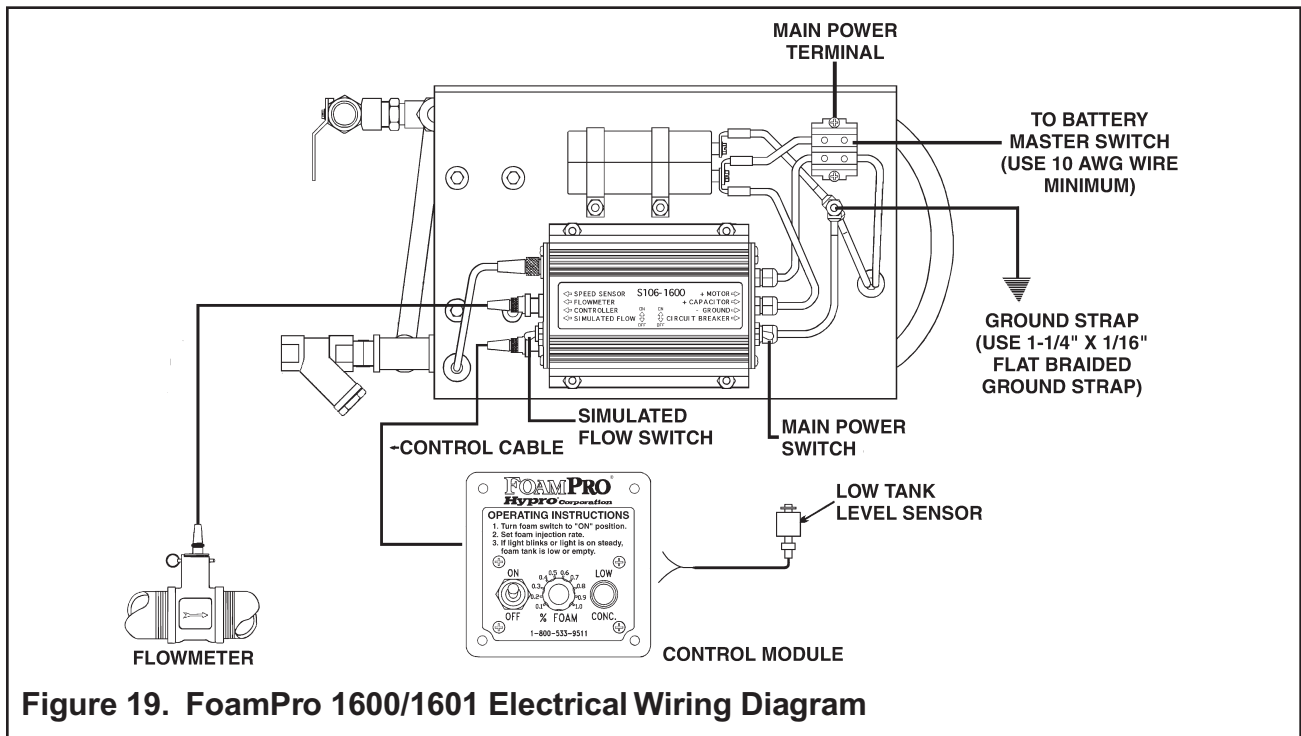
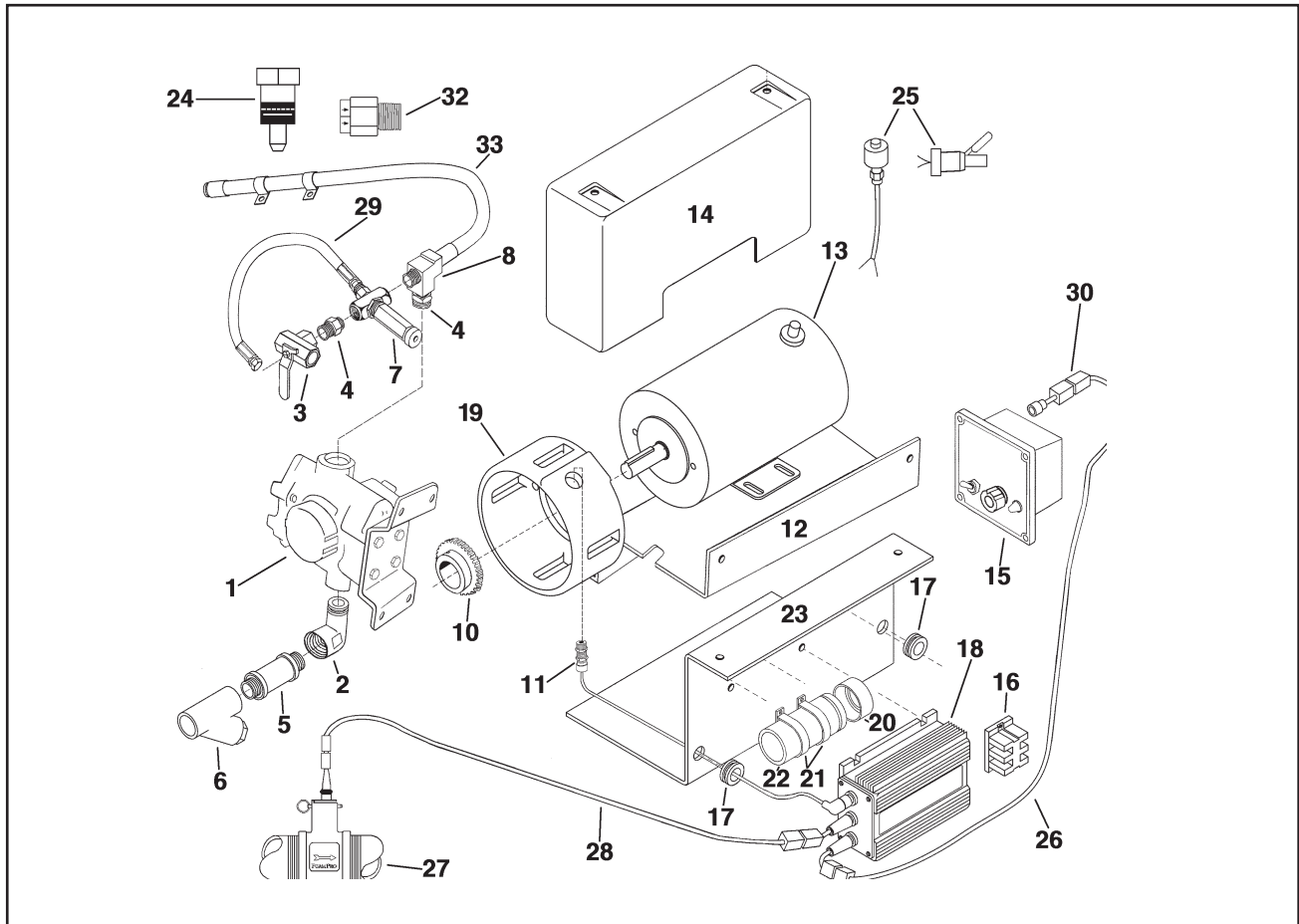

Figure 19. FoamPro 1600/1601 Electrical Wiring Diagram

TROUBLESHOOTING GUIDE

Symptom	Probable Cause(s)	Corrective Action
Pump runs but produces no flow.	Pump is not primed.	See Foam Pump Priming Check section on Page 18.
Pump loses prime, chattering noise, pressure fluctuates.	Air leak in suction hose or inlet fittings.	Remove suction hose and test for leaks by pressurizing hose with water. Make sure thread sealant has been used on all fittings.
	Suction line is blocked, collapsed or too small.	Remove suction line and inspect it for a loose line or debris lodged in hose. Avoid all unnecessary bends. Do not kink hose.
	Clogged suction strainer.	Clean strainer.
LOW CONC. light blinks five times per second.	Speed sensor circuit open.	Inspect wiring and connection to speed sensor.
	Sensor position incorrect.	Check to ensure that the speed sensor is within the proper sensing distance of .005 to .015 inches from the pulley teeth.
	Speed sensor not functioning.	Replace speed sensor.
	Inadequate ground.	Inspect wiring and ground connection.
Pump runs full speed whenever the switch is in "ON" or "OFF"	Defective driver box.	Replace box.
Light does not flash "ON" when system is first turned on.	Note: The main switch is current limited to 32 amps for 12 VDC systems and 16 amps for 24 VDC systems.	
	The main power switch is not "ON".	Turn on the main power switch on the motor driver module.
	Cables not correctly connected.	Inspect and secure connections.
	Inadequate ground.	Inspect wiring and ground connection.
	Control cable(s) defective.	Replace control cable(s).
	Inadequate voltage.	Check voltage at system connection.
System is powered up and the Foam ON/OFF switch is on, but the foam pump doesn't run.	No water is flowing in any of the foam discharges.	Flow water.
	Flowmeter wiring not correct.	Inspect wiring and connection to flow meter.
	Flowmeter obstructed.	Clean or clear flow meter of debris.
	Flowmeter not functioning.	Replace flow meter.
	Inadequate ground.	Inspect wiring and ground connection.
	Control cable(s) defective.	Check connections and replace control cable(s).
LO.CONC. light goes on and stays on or light blinks once per second.	Concentrate level in tank is low.	Fill concentrate tank.
	Low tank level sensor or wiring is inoperative.	Repair or replace defective components.
	Float is on plunger wrong—indicating tank is low.	Remove the snap ring at the top of the plunger and remove the float, turn it over and reinstall.
	Float stuck on plunger—indicating tank is low.	Inspect and clean float switch.
CAL/INJECT valve is leaking.	Valve seat is loose.	Remove hose and fitting from inject port of valve and tighten seat using 3/8 inch hex wrench. Reconnect fitting and hose.
Pump runs without water flow.	Simulated flow switch in "on" position.	Turn it to "off" position.

13 PARTS IDENTIFICATION



Ref.	Part No.	Description	Qty.	Ref.	Part No.	Description	Qty.
1	53709	Plunger Pump for Model 1600	1	22	2530-0061	Capacitor (82000mF, 25VDC)	1
1	53708	Plunger Pump for Model 1601	1	23	1510-0089	Mounting Bracket	1
2	2401-0035	Elbow, 1/2 inch NPT	1	24	2404-0182	Injector Fitting	1
3	3304-0025	Cal./Inject Valve	1	25	2510-0028	Tank Level Sensor (Vertical)	1
4	2404-0271	Reducer	2		2510-0032	Tank Level Sensor (Side)	1
5	2401-0038	Tee, 1/2 inch NPT	1	26	2520-0048	Control Cable (6 ft. [2 m] Lg) (Std.)	1
6	3350-0135	Line Strainer	1		2520-0049	Control Cable (12 ft. [3 m] Lg)	1
7	3300-0092	Relief Valve	1	27	2660-0030	Flowmeter, 1-1/2 inch NPT x 1 inch bore	1
8	2401-0019	Tee, 3/8 inch NPT	1	27	2660-0031	Flowmeter, 1-1/2 inch NPT	1
10	3900-0050	Gear	1	27	2660-0032	Flowmeter, 2 inch NPT	1
11	2530-0064	Speed Sensor	1	27	2660-0031B	Flowmeter, 1-1/2 inch BSP	1
12	1520-0059	Pump/Motor Bracket	1	27	2660-0032B	Flowmeter, 2 inch BSP	1
13	2570-0023	Electric Motor (12V DC)	1	28	2520-0045	Flowmeter Cable (6 ft. [2 m] Lg)(Std)	1
13	2570-0024	Electric Motor (24V DC)	1		2520-0046	Flowmeter Cable (12 ft. [3 m] Lg)	1
14	2840-0077	Cover	1	29	2900-0049	By-Pass Hose	1
15	2527-0056	Control Module	1	30	3430-0351	RFI Suppression Kit (4 pcs)	1
16	2530-0096	Terminal Block	1	31	6031-0334	Operators Instructional Label	1
17	1700-0102	Grommet	2	32	3320-0027	Check Valve, 1/2 inch	1
18	2527-0070	Motor Driver Box (12V DC)	1	33	3375-0011	Pulse Hose	1
18	2527-0072	Motor Driver Box (24V DC)	1				
19	2840-0081A	Shield	1				
20	1450-0010	Plastic Cap	1				
21	2910-0011	Clamp, Vinyl Coated	2				

14 CONTROL MODULE TEMPLATE

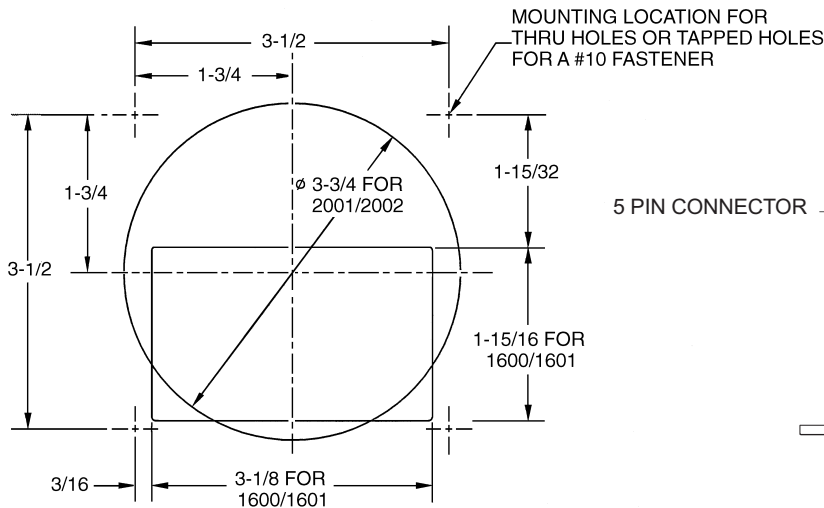

Panel Cutout Pattern

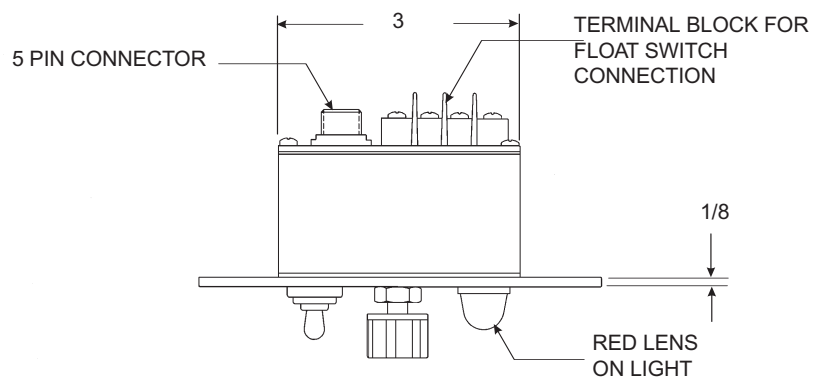

Control Module (top view)

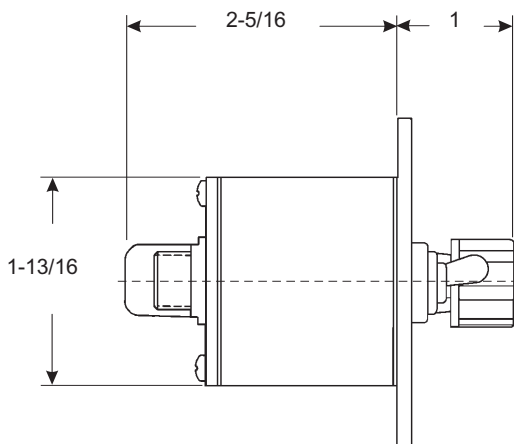

Control Module (side view)

Additional space (3") is required for cables.

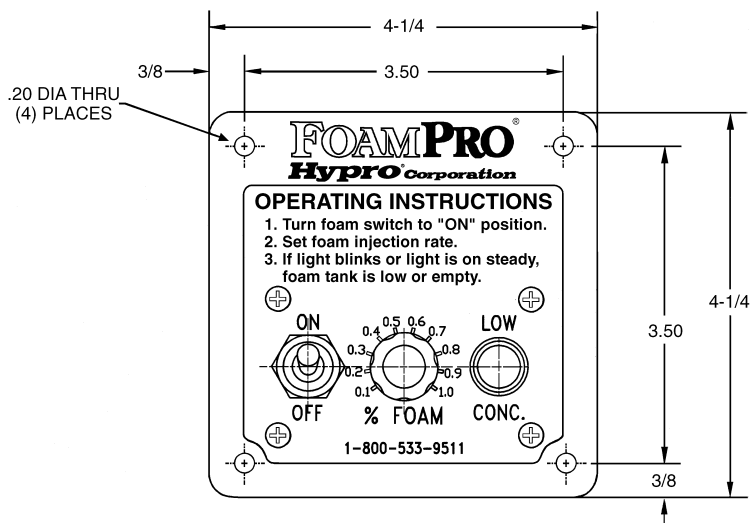

Control Module (front view)

FoamPro Flowmeter

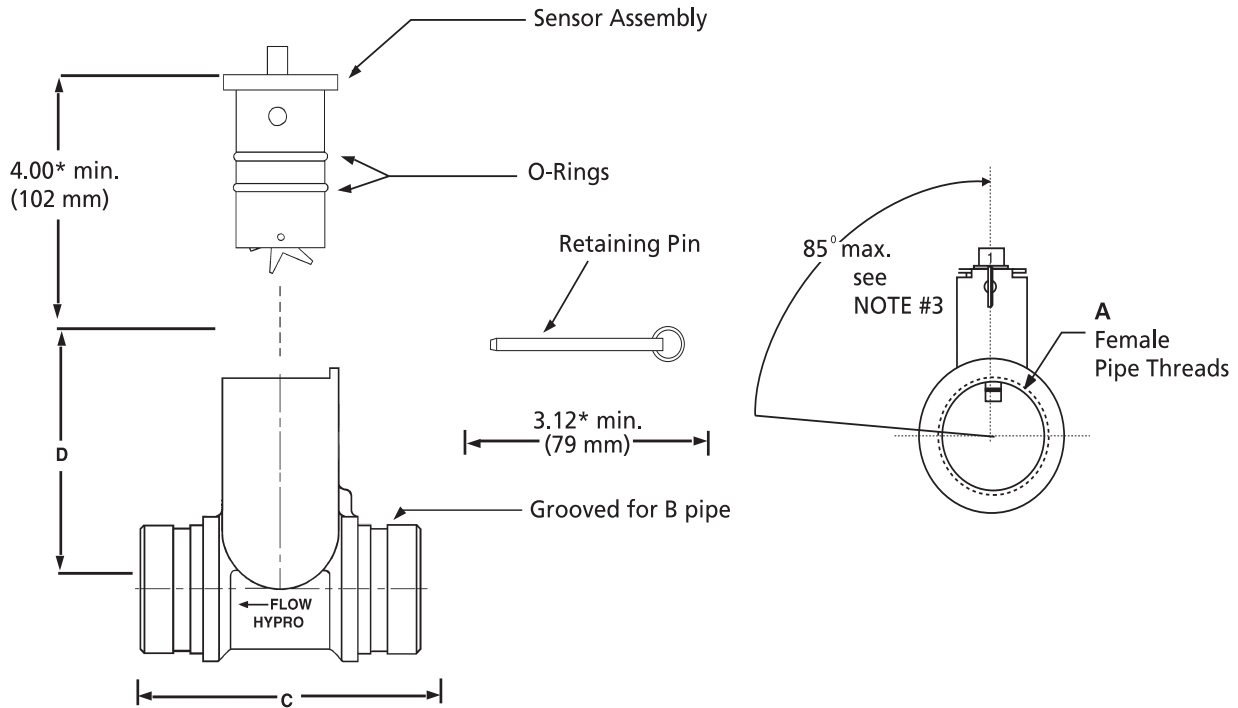

* = Minimum sensor service clearance.

- NOTE:**
1. Use **CAUTION** not to damage sensor during assembly.
 2. Use **Loctite® PST 565** or equivalent Teflon tape to seal pipe threads.
 3. **Maximum horizontal installation angle to allow proper water drainage. Unit may also be installed in vertical piping arrangement.**

Assy. Part Number	A	B	C	D	Maximum Accuracy Flow Range (gpm)	Maximum Operating Flow Range (gpm)
2660-0030	1-1/2"—11-1/2" NPT NOTE 1" I.D. Bore	2" Pipe	7-3/8" [188 mm]	3-7/8" [99 mm]	5-110	3-145
2660-0031	1-1/2"—11-1/2" NPT	2" Pipe	5-3/8" [137 mm]	4-1/8" [105 mm]	10-320	3-380
2660-0031B	1-1/2"—11" BSP	2" Pipe	5-3/8" [137 mm]	4-1/8" [105 mm]	10-320	3-380
2660-0032	2"—11-1/2" NPT	2-1/2" Pipe	5-3/8" [137 mm]	4-3/8" [111 mm]	15-520	5-625
2660-0032B	2"—11" BSP	2-1/2" Pipe	5-3/8" [137 mm]	4-3/8" [111 mm]	15-520	5-625

15 WARRANTY

Hypro, as supplier of FoamPro, warrants to the original purchaser, each new pump, system or other product of its own manufacture, for a period of one year from the date of shipment from the factory, to be free from defects in material and workmanship under normal use and service. "Normal use and service" means not in excess of recommended maximum speeds, pressures, and temperatures, or handling fluids not compatible with components materials, as noted in applicable Hypro product catalogs, technical literature, and instructions. This warranty shall not apply to any pump, system or other product which shall have been repaired or altered to adversely affect the performance or reliability of the pump, system or other product.

Neither this warranty nor any implied warranty apply to damage or harm caused by any or all of the following: (1) Freight damage; (2) Freezing damage; (3) Damage caused by parts and/or accessories or components not obtained from or approved by Hypro; (4) ANY CONSEQUENTIAL OR INCIDENTAL DAMAGES, OTHER THAN INJURY TO THE PERSON, ARISING FROM THE USE OF ANY PUMP OR OTHER PRODUCT MANUFACTURED BY HYPRO EXCEPT in states that do not allow the exclusion or limitation of incidental or consequential damages; (5) Damage due to misapplication and/or misuse; (6) Normal wear of moving parts or components affected by moving parts.

The liability of Hypro under the foregoing warranty is limited to the repair or replacement at Hypro's option without charge for labor or materials of any parts upon return of the entire pump, system or other product or of the particular part to the Hypro factory within the warranty period, at the sole expense of the purchaser, which part shall upon examination appear to Hypro's satisfaction to have been defective in material and workmanship.

The liability of Hypro under any theory of recovery (except any express warranty where the remedy is set forth in the above paragraph) for loss, harm or damage, shall be limited to the lesser of the actual loss, harm or damage or the purchase price of the involved pump, system or other product when sold by Hypro to its customer.

Hypro expressly warrants its pumps and other products as above stated. THERE ARE NO OTHER EXPRESS WARRANTIES. ANY IMPLIED WARRANTIES, INCLUDING IMPLIED WARRANTY OF MERCHANTABILITY OR OF FITNESS FOR A PARTICULAR PURPOSE, ARE LIMITED IN DURATION TO ONE YEAR FROM THE DATE OF PURCHASE BY THE ORIGINAL PURCHASER EXCEPT in states that do not allow time limitations on implied warranties. THERE IS NO IMPLIED WARRANTY OF FITNESS FOR A PARTICULAR PURPOSE OR MERCHANTABILITY WHEN THIS PRODUCT IS PUT TO RENTAL USE.

No person including any dealer or representative of FoamPro is authorized to make any representation or warranty concerning Hypro's FoamPro products on behalf of Hypro, or to assume for Hypro the obligations contained in this warranty. Hypro reserves the right to make changes in design and other changes and improvements upon its products without imposing any obligations upon itself to install the same, upon its existing products then in process or manufacture.

This warranty gives you specific legal rights, and you may also have other rights which vary from state to state.

IMPORTANT NOTICE

It is imperative to package all FoamPro components properly, **before** shipment (with Return Goods Authorization attached) back to Hypro. The FoamPro contains electronic components that may receive damage from improper shipping procedures! All FoamPro components shipped back to Hypro will pass through Quality Control Inspection, and will be photographed after the box is opened. Any shipping damage, such as superficial scratches, nicks, etc., to the unit makes it unusable (even after the internal warranty problem is repaired) and thus must be refinished to "like-new" condition during the warranty process. *You are responsible for any physical damage occurring to FoamPro components at your facility and during shipment back to Hypro.*

Package the FoamPro, complete with all the recommended parts the Customer Service representative requires (i.e., Digital Display control with all premolded wire cables etc.) in its original carton with the Styrofoam and other packaging materials, as it was received at your facility.

Hypro appreciates your attention in this matter, as we feel it will help us to serve you in a better fashion, while keeping the cost of the FoamPro product competitive. Thank you.